

+5V Powered Dual RS-232 Transmitter/Receiver

December 1993

Features

- Meets All RS-232C Specifications
- Requires Only Single +5V Power Supply
- Onboard Voltage Doubler/Inverter
- Low Power Consumption
- 2 Drivers
 - $\pm 9V$ Output Swing for +5V Input
 - 300Ω Power-off Source Impedance
 - Output Current Limiting
 - TTL/CMOS Compatible
 - $30V/\mu s$ Maximum Slew Rate
- 2 Receivers
 - $\pm 30V$ Input Voltage Range
 - $3k\Omega$ to $7k\Omega$ Input Impedance
 - 0.5V Hysteresis to Improve Noise Rejection
- All Critical Parameters are Guaranteed Over the Entire Commercial, Industrial and Military Temperature Ranges

Applications

- Any System Requiring RS-232 Communications Port
 - Computer - Portable and Mainframe
 - Peripheral - Printers and Terminals
 - Portable Instrumentation
 - Modems
 - Dataloggers

Description

The ICL232 is a dual RS-232 transmitter/receiver interface circuit that meets all EIA RS-232C specifications. It requires a single +5V power supply, and features two onboard charge pump voltage converters which generate +10V and -10V supplies from the 5V supply.

The drivers feature true TTL/CMOS input compatibility, slew-rate-limited output, and 300Ω power-off source impedance. The receivers can handle up to +30V, and have a $3k\Omega$ to $7k\Omega$ input impedance. The receivers also have hysteresis to improve noise rejection.

Ordering Information

PART NUMBER	TEMPERATURE RANGE	PACKAGE
ICL232CPE	0°C to +70°C	16 Lead Plastic DIP
ICL232CJE	0°C to +70°C	16 Lead Ceramic DIP
ICL232CBE	0°C to +70°C	16 Lead SOIC (W)
ICL232IPE	-40°C to +85°C	16 Lead Plastic DIP
ICL232IJE	-40°C to +85°C	16 Lead Ceramic DIP
ICL232IBE	-40°C to +85°C	16 Lead SOIC (W)
ICL232MJE	-55°C to +125°C	16 Lead Ceramic DIP

Pinouts

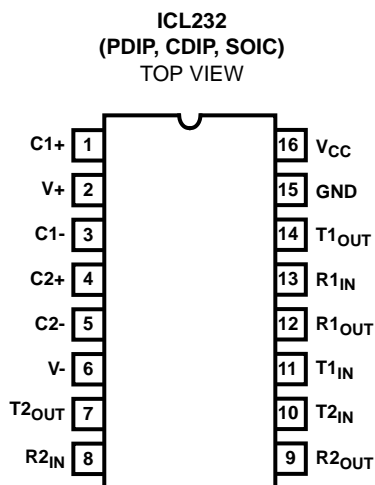

Functional Diagram

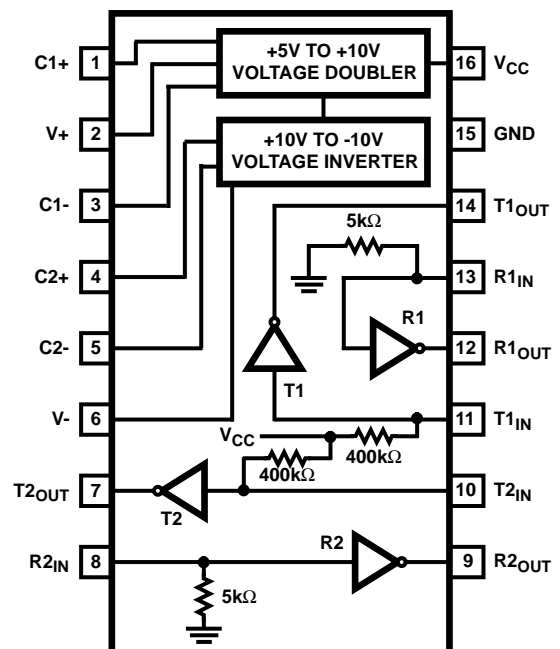

Specifications ICL232

Absolute Maximum Ratings

V_{CC} to Ground	(GND -0.3V) < V_{CC} < 6V
V+ to Ground	(V_{CC} -0.3V) < V+ < 12V
V- to Ground	-12V < V- < (GND +0.3V)
Input Voltages	
T1 _{IN} , T2 _{IN}	(V- -0.3V) < V _{IN} < (V+ +0.3V)
R1 _{IN} , R2 _{IN}	±30V
Output Voltages	
T1 _{OUT} , T2 _{OUT}	(V- -0.3V) < V _{TXOUT} < (V+ +0.3V)
R1 _{OUT} , R2 _{OUT}	(GND -0.3V) < V _{RXOUT} < (V _{CC} +0.3V)
Short Circuit Duration	
T1 _{OUT} , T2 _{OUT}	Continuous
R1 _{OUT} , R2 _{OUT}	Continuous
Storage Temperature Range	-65°C to +150°C
Lead Temperature (Soldering 10s)	+300°C

Thermal Information

Thermal Resistance	θ_{JA}	θ_{JC}
Ceramic DIP Package	80°C/W	24°C/W
Plastic DIP Package	100°C/W	-
SOIC Package	100°C/W	-
Maximum Power Dissipation	250mW	
Operating Temperature Range		
ICL232C	0°C to +70°C	
ICL232I	-40°C to +85°C	
ICL232M	-55°C to +125°C	

CAUTION: Stresses above those listed in "Absolute Maximum Ratings" may cause permanent damage to the device. This is a stress only rating and operation of the device at these or any other conditions above those indicated in the operational sections of this specification is not implied.

Electrical Specifications

Test Conditions: $V_{CC} = +5V \pm 10\%$, $T_A =$ Operating Temperature Range. Test Circuit as in Figure 8 Unless Otherwise Specified

PARAMETER	TEST CONDITIONS	LIMITS			UNITS
		MIN	TYP	MAX	
Transmitter Output Voltage Swing, T _{OUT}	T1 _{OUT} and T2 _{OUT} loaded with 3kΩ to Ground	±5	±9	±10	V
Power Supply Current, I _{CC}	Outputs Unloaded, T _A = +25°C	-	5	10	mA
T _{IN} , Input Logic Low, V _{IL}		-	-	0.8	V
T _{IN} , Input Logic High, V _{IH}		2.0	-	-	V
Logic Pullup Current, I _P	T1 _{IN} , T2 _{IN} = 0V	-	15	200	μA
RS-232 Input Voltage Range, V _{IN}		-30	-	+30	V
Receiver Input Impedance, R _{IN}	V _{IN} = ±3V	3.0	5.0	7.0	kΩ
Receiver Input Low Threshold, V _{IN} (H-L)	V _{CC} = 5.0V, T _A = +25°C	0.8	1.2	-	V
Receiver Input High Threshold, V _{IN} (L-H)	V _{CC} = 5.0V, T _A = +25°C	-	1.7	2.4	V
Receiver Input Hysteresis, V _{HYST}		0.2	0.5	1.0	V
TTL/CMOS Receiver Output Voltage Low, V _{OL}	I _{OUT} = 3.2mA	-	0.1	0.4	V
TTL/CMOS Receiver Output Voltage High, V _{OH}	I _{OUT} = -1.0mA	3.5	4.6	-	V
Propagation Delay, t _{PD}	RS-232 to TTL	-	0.5	-	μs
Instantaneous Slew Rate, SR	C _L = 10pF, R _L = 3kΩ, T _A = +25°C (Notes 1, 2)	-	-	30	V/μs
Transition Region Slew Rate, SR _T	R _L = 3kΩ, C _L = 2500pF Measured from +3V to -3V or -3V to +3V	-	3	-	V/μs
Output Resistance, R _{OUT}	V _{CC} = V+ = V- = 0V, V _{OUT} = ±2V	300	-	-	Ω
RS-232 Output Short Circuit Current, I _{SC}	T1 _{OUT} or T2 _{OUT} shorted to GND	-	±10	-	mA

NOTES:

1. Guaranteed by design.
2. See Figure 4 for definition.

Typical Performance Curves

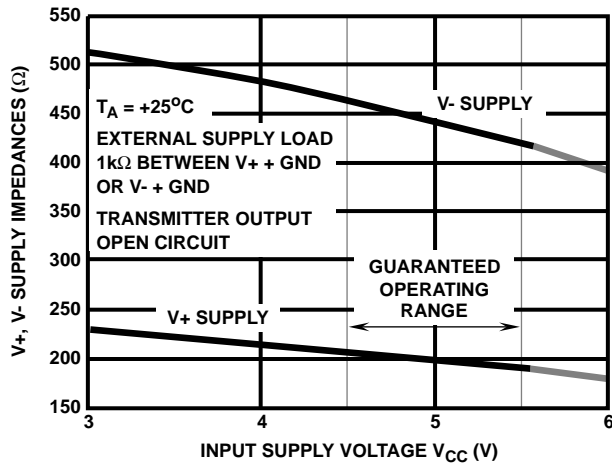

FIGURE 1. V+, V- OUTPUT IMPEDANCES vs V_{CC}

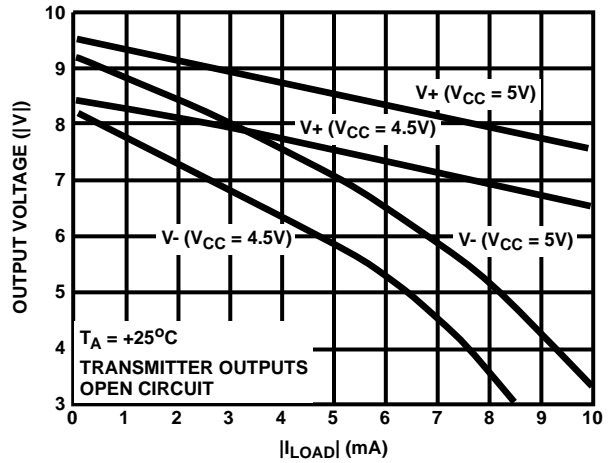

FIGURE 2. V+, V- OUTPUT VOLTAGES vs LOAD CURRENT

Pin Descriptions

PLASTIC DIP, CERAMIC DIP	SOIC	PIN NAME	DESCRIPTION
1	1	C1+	External capacitor "+" for internal voltage doubler.
2	2	V+	Internally generated +10V (typical) supply.
3	3	C1-	External capacitor "-" for internal voltage doubler.
4	4	C2+	External capacitor "+" internal voltage inverter.
5	5	C2-	External capacitor "-" internal voltage inverter.
6	6	V-	Internally generated -10V (typical) supply.
7	7	T2 _{OUT}	RS-232 Transmitter 2 output ±10V (typical).
8	8	R2 _{IN}	RS-232 Receiver 2 input, with internal 5K pulldown resistor to GND.
9	9	R2 _{out}	Receiver 2 TTL/CMOS output.
10	10	T2 _{IN}	Transmitter 2 TTL/CMOS input, with internal 400K pullup resistor to V _{CC} .
11	11	T1 _{IN}	Transmitter 1 TTL/CMOS input, with internal 400K pullup resistor to V _{CC} .
12	12	R1 _{OUT}	Receiver 1 TTL/CMOS output.
13	13	R1 _{IN}	RS-232 Receiver 1 input, with internal 5K pulldown resistor to GND.
14	14	T1 _{OUT}	RS-232 Transmitter 1 output ±10V (typical).
15	15	GND	Supply Ground.
16	16	VCC	Positive Power Supply +5V ±10%

Detailed Description

The ICL232 is a dual RS-232 transmitter/receiver powered by a single +5V power supply which meets all EIA RS232C specifications and features low power consumption. The functional diagram illustrates the major elements of the ICL232. The circuit is divided into three sections: a voltage doubler/inverter, dual transmitters, and dual receivers.

Voltage Converter

An equivalent circuit of the dual charge pump is illustrated in Figure 3.

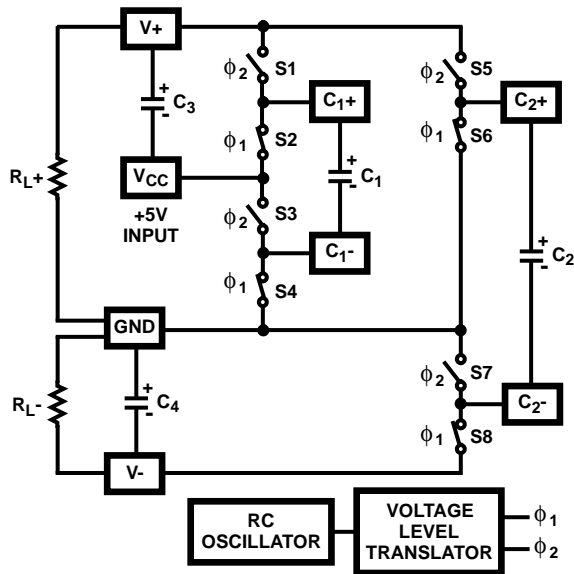

FIGURE 3. DUAL CHARGE PUMP

The voltage quadrupler contains two charge pumps which use two phases of an internally generated clock to generate +10V and -10V. The nominal clock frequency is 16kHz. During phase one of the clock, capacitor C1 is charged to V_{CC} . During phase two, the voltage on C1 is added to V_{CC} , producing a signal across C2 equal to twice V_{CC} . At the same time, C3 is also charged to $2V_{CC}$, and then during phase one, it is inverted with respect to ground to produce a signal across C4 equal to $-2V_{CC}$. The voltage converter accepts input voltages up to 5.5V. The output impedance of the doubler (V+) is approximately 200Ω , and the output impedance of the inverter (V-) is approximately 450Ω . Typical graphs are presented which show the voltage converters output vs input voltage and output voltages vs load characteristics. The test circuit (Figure 8) uses $1\mu F$ capacitors for C1-C4, however, the value is not critical. Increasing the values of C1 and C2 will lower the output impedance of the voltage doubler and inverter, and increasing the values of the reservoir capacitors, C3 and C4, lowers the ripple on the V+ and V- supplies.

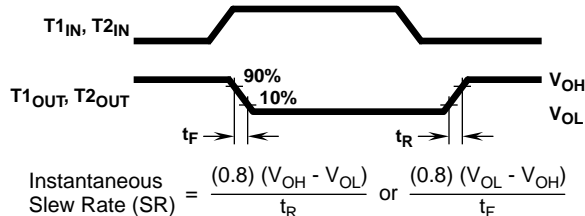

FIGURE 4. SLEW RATE DEFINITION

Transmitters

The transmitters are TTL/CMOS compatible inverters which translate the inputs to RS-232 outputs. The input logic threshold is about 26% of V_{CC} , or 1.3V for $V_{CC} = 5V$. A logic 1 at the input results in a voltage of between $-5V$ and V^- at the output, and a logic 0 results in a voltage between $+5V$ and $(V^+ - 0.6V)$. Each transmitter input has an internal $400k\Omega$ pullup resistor so any unused input can be left unconnected and its output remains in its low state. The output voltage swing meets the RS-232C specification of $\pm 5V$ minimum with the worst case conditions of: both transmitters driving $3k\Omega$ minimum load impedance, $V_{CC} = 4.5V$, and maximum allowable operating temperature. The transmitters have an internally limited output slew rate which is less than $30V/\mu s$. The outputs are short circuit protected and can be shorted to ground indefinitely. The powered down output impedance is a minimum of 300Ω with $\pm 2V$ applied to the outputs and $V_{CC} = 0V$.

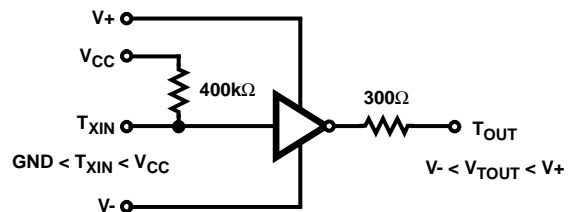

FIGURE 5. TRANSMITTER

Receivers

The receiver inputs accept up to $\pm 30V$ while presenting the required $3k\Omega$ to $7k\Omega$ input impedance even if the power is off ($V_{CC} = 0V$). The receivers have a typical input threshold of 1.3V which is within the $\pm 3V$ limits, known as the transition region, of the RS-232 specification. The receiver output is $0V$ to V_{CC} . The output will be low whenever the input is greater than 2.4V and high whenever the input is floating or driven between $+0.8V$ and $-30V$. The receivers feature 0.5V hysteresis to improve noise rejection.

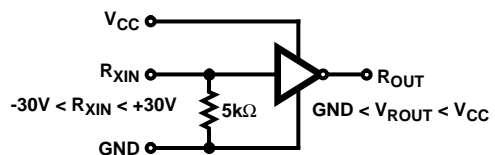
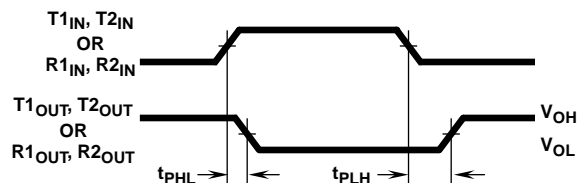

FIGURE 6. RECEIVER



$$\text{Average Propagation Delay} = \frac{t_{PHL} + t_{PLH}}{2}$$

FIGURE 7. PROPAGATION DELAY DEFINITION

Test Circuits

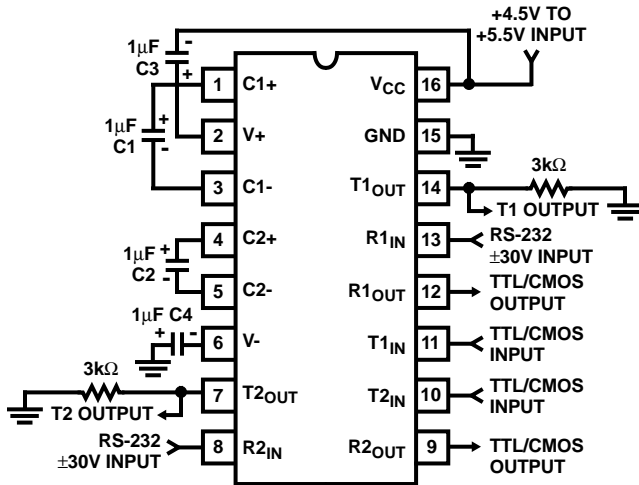

FIGURE 8. GENERAL TEST CIRCUIT

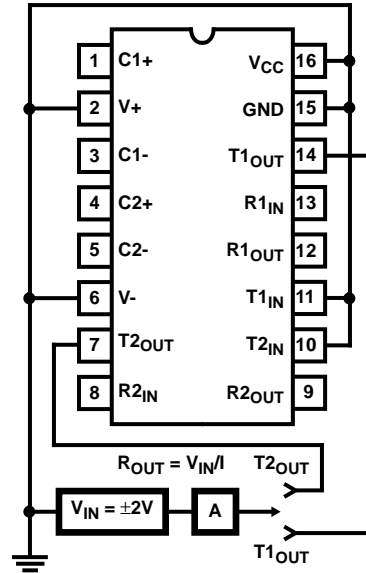

FIGURE 9. POWER-OFF SOURCE RESISTANCE CONFIGURATION

Applications

The ICL232 may be used for all RS-232 data terminal and communication links. It is particularly useful in applications where ±12V power supplies are not available for conventional RS-232 interface circuits. The applications presented represent typical interface configurations.

A simple duplex RS-232 port with CTS/RTS handshaking is illustrated in Figure 10. Fixed output signals such as DTR (data terminal ready) and DSRS (data signaling rate select) is generated by driving them through a 5kΩ resistor connected to V+.

capacitors (C3 and C4). The benefit of sharing common reservoir capacitors is the elimination of two capacitors and the reduction of the charge pump source impedance which effectively increases the output swing of the transmitters.

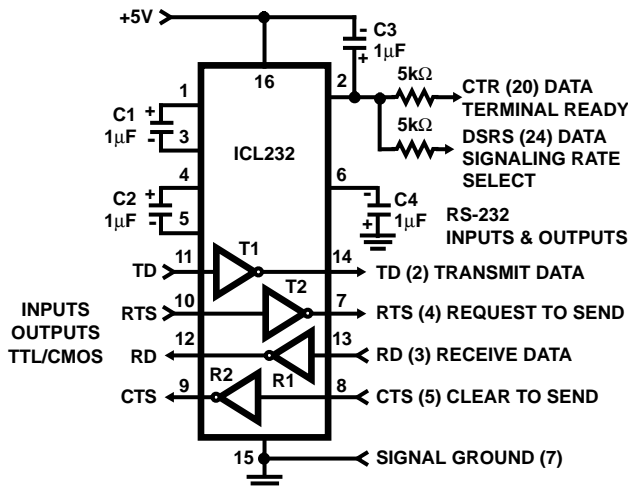

FIGURE 10. SIMPLE DUPLEX RS-232 PORT WITH CTS/RTS HANDSHAKING

In applications requiring four RS-232 inputs and outputs (Figure 11), note that each circuit requires two charge pump capacitors (C1 and C2) but can share common reservoir

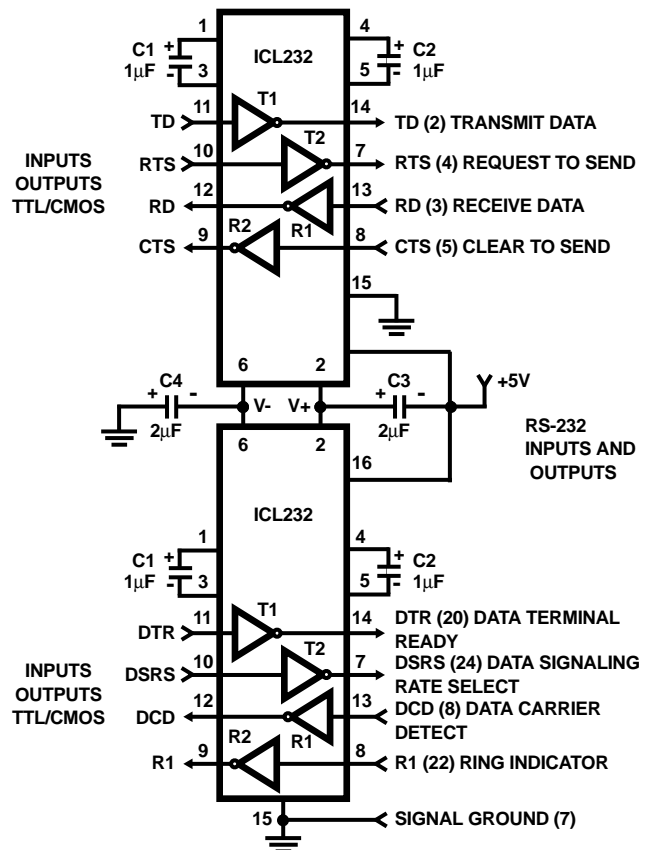

FIGURE 11. COMBINING TWO ICL232s FOR 4 PAIRS OF RS-232 INPUTS AND OUTPUTS